

26/01/2015

BC9 SERIES

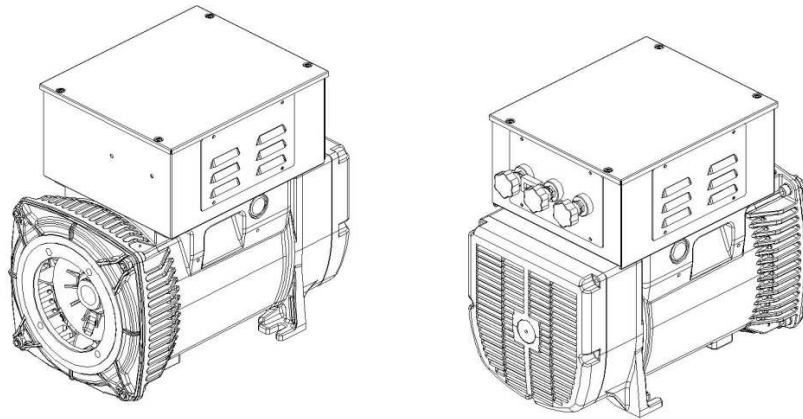

MAIN FEATURES



- Nine phase AC source
- Brushless alternator
- From 1050 to 3000 RPM
- Dc output voltage: 12Vdc , 24Vdc, 48Vdc or 72Vdc
- Power output: 2.2 Kw @12Vdc, 4.3 kW @24Vdc , 8.4kW @48Vdc and 13 kW @72Vdc
- DC output current up to 150A dc
- AVR output voltage control
- Output current limiter
- Eighteen pulses DC power rectifier
- Over-excitation protection (included in AVR)
- Under-speed protection (included in AVR)
- Output voltage accuracy $\pm 1\%$
- Thermal trip protections (windings and power rectifier)
- Output ripple $< 1\%$ without battery
- External fuse protection
- Aluminium frame

TECHNICAL DATA

DC output (Vdc)	12 ÷ 14,4	24 ÷ 28,8	48 ÷ 56	72 ÷ 86,4
Power outlet	2,2 Kw	4,3 Kw	8,4 Kw	13 Kw
Max DC output current	150A			
Max Efficiency	86%			
Reliability	High due to the use of diode technology			
RPM	From 1050 to 3000 RPM ¹			
Output ripple	< 1% (see picture 1)			
Output accuracy	± 1%			

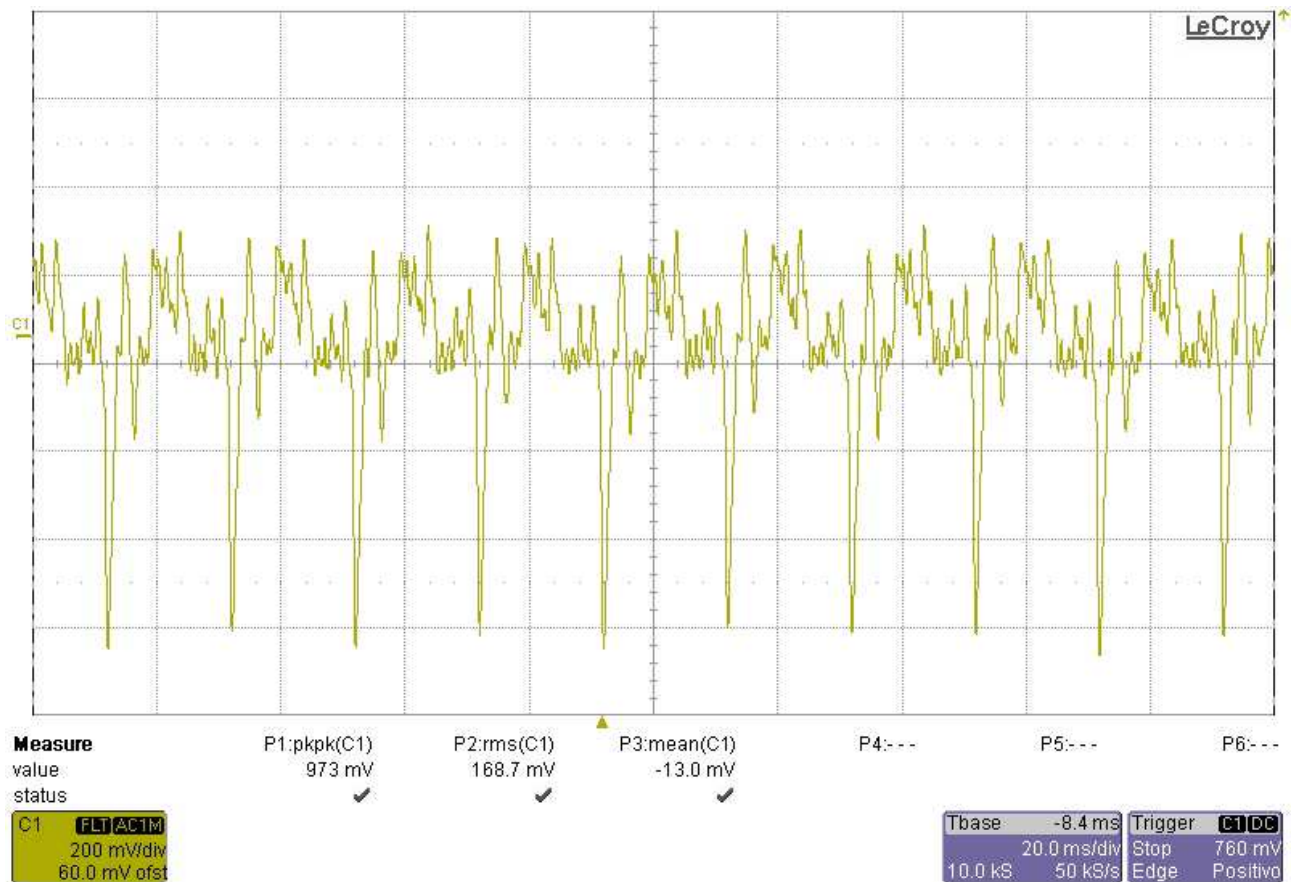

Picture 1: AC ripple waveform @ 28V_{DC} and 150A_{DC} output. The RMS value of the ripple is 168.7mV that is 0.6% of the nominal output voltage.

¹ Efficiency and power outlet are affected by RPM.

ELECTRIC DIAGRAM

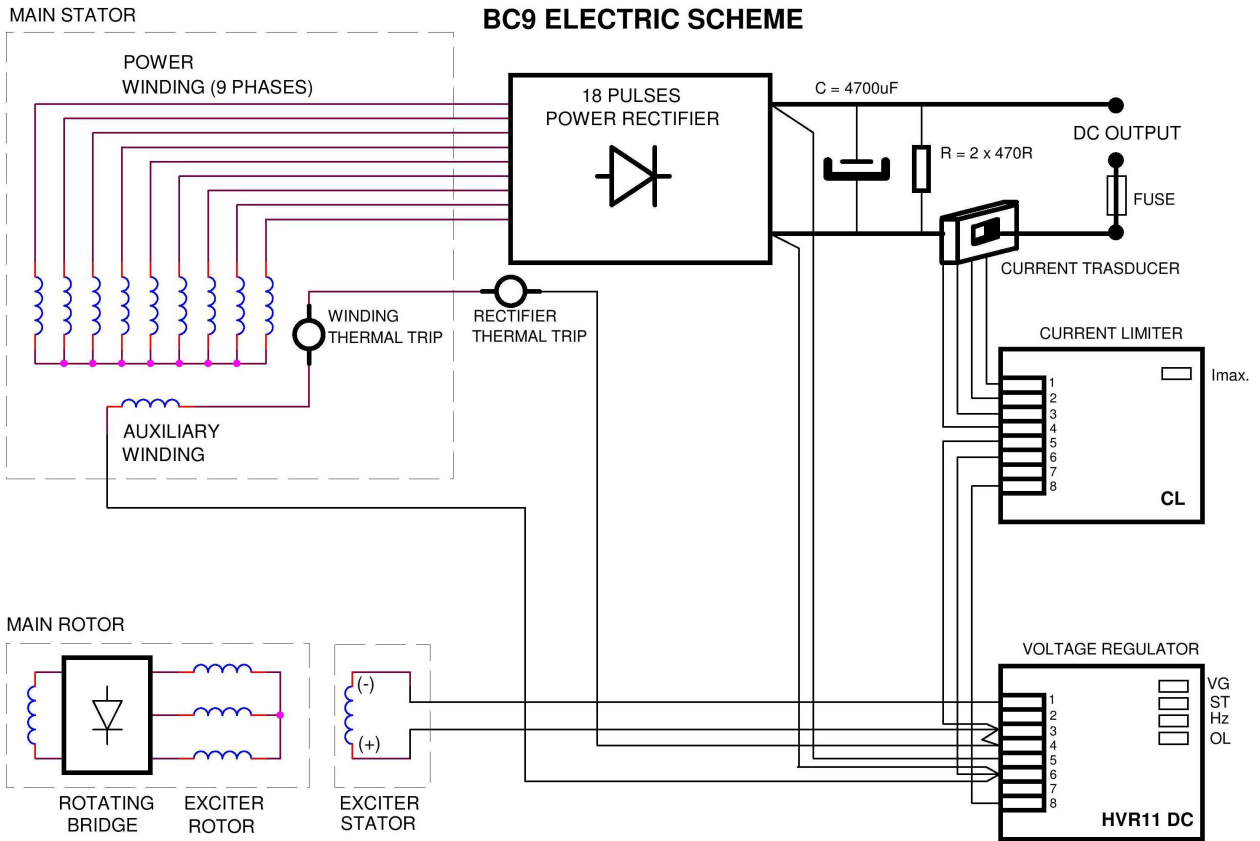

VG: Voltage trimmer, the voltage increases in clockwise direction
 ST: Stability trimmer, the stability increases in clockwise direction
 Hz: Under frequency trimmer, the protection is OFF in clockwise direction
 OL: Overload trimmer, the protection is OFF in clockwise direction

BC9 PHOTOS DURING TEST

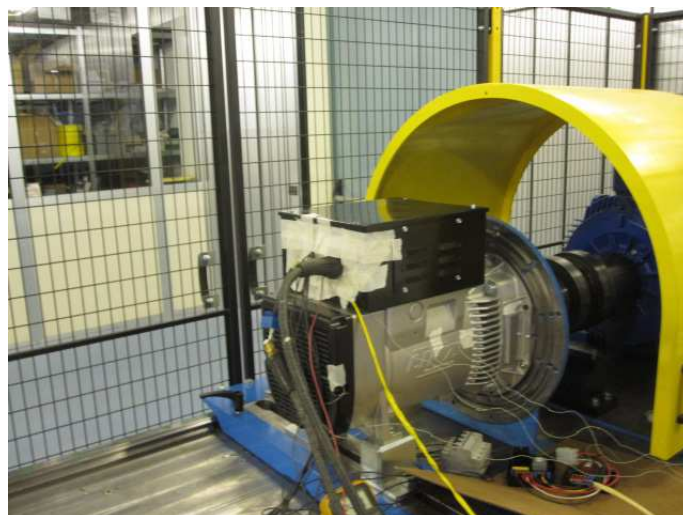
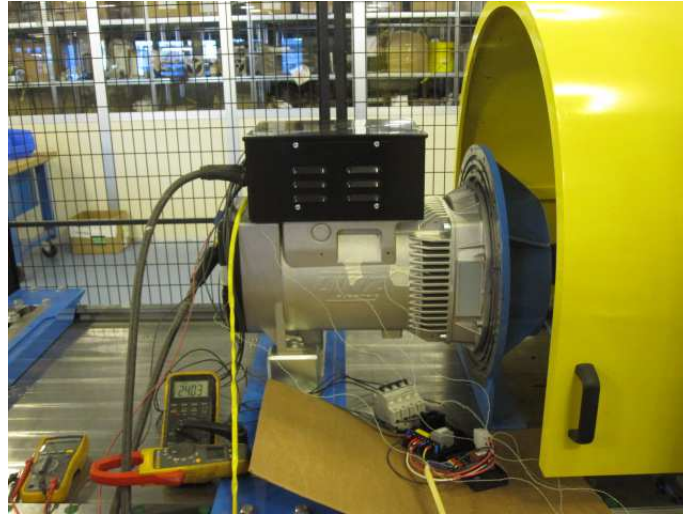



LINZ ELECTRIC S.p.A. V.le del Lavoro 30 – 37040 ARCOLE (VR) ITALIA – C.F./P.IVA IT01954820237

Tel. +39-045-7639201 - Fax +39-045-7639202 - info@linzelectric.com - www.linzelectric.com
